

MODULE SEIRES, LIGHTDIMMER CP33LR, 3-CHANNELS, LEADING EDGE

Light Dimmer CP33LR

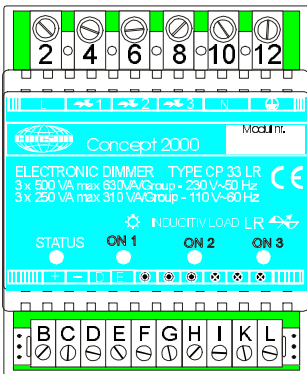

EAN-No. 5703513005887

Description

CP33LR is a DIN rail based (2 M36 units 72 mm) 3-channel light dimmer for ohmic and inductive leading edge Triac control of 110/230vac glow lamps, halogen, traditional coiled transformers for low-volt halogen and HF coils for direct dimming.

CP33LR uses logarithmic dimming control and offers softstart, softstop as well as thermal protection and detection of null-wire breakage.

Each of the 3 channels may control up to 500 VA, but the total control must not exceed 630 VA.

Each of the 3 channels are individually operated. Either by means of ground-active input F(1), G(2) and H(3) or by bus-instructions from one or more command modules as f.ex. Switch-link CP20 and/or Remote-link CP70.

Each of the 3 channels have a related indicator output (open collector, max. 75 mA) which may be connected to Sesam touchpanel indicators or a monitor panel.

The 3 channels may work together as as group controlling 4 user-programmable light scenes. Step through the factory pre-programmed scenes using Step input D, toggle all 3 channels On/Off or dim Up/Down using On/Off input E, taking advantage of the built-in light scene memory.

Programmable settling delays offers smooth changes between light scenes.

Programming of the CP33LR is achieved by means of CONKEY CP79 or a PC.

CP33LR offers more than 33 functions: (Also see 'Action-Table')

- Step through light scenes via input D
- Light scene settling timing
- Light scenes via Link-modules
- Group ON/OFF via input E
- Group dimming via input E
- Light dimming via switch input F, G and H
- Light dimming via Link-modules
- Fade timing
- "Sleep timer"-function
- Programming Output Confirmation (NEW)
- All ON / All OFF - and much more

Light scenes example:

	3 lamps controlled by 1 qty. light dimmer CP33LR		
	DINNER TABLE	WALL LAMP	CEILING
Daily	70%	50%	50%
Light scene 1 RELAX	40%	20%	40%
Light scene 2 GUESTS	50%	80%	60%
Light scene 3 TELEVISION	10%	40%	30%
Light scene 4 CLEANING	100%	100%	100%
ALL OFF	0%	0%	0%

Load types for CP33LR:

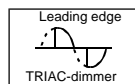

Leading edge dimmer 40-630 VA for ohmic and inductive load (TRIAC)

L = Inductive load:

- Traditional transformers for low-volt halogen-lamps
- Electronic transformers (leading edge) for low-volt halogen lamps.

R = Ohmic load:

- Glow lamps
- 110/230V halogen lamps

Connections for CP33LR

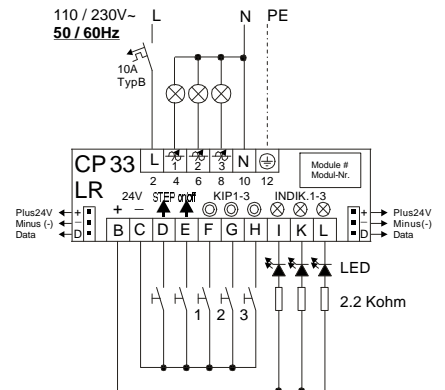

Inputs for CP33LR:

High current	Symbol	Comments
Input 2	L	Phase
Output 4	⊗	Regulated phase 1
Output 6	⊗	Regulated phase 2
Output 8	⊗	Regulated phase 3
Output 10	N	Null-wire
Input 12	⊕	Earth
Low current		
Input B	+	Plus 24V DC
Input C	-	Minus (-)
Input D	D	Step light scenes
Input E	E	On/Off all channels
Input F	⊙	channel input 1 (-)
Input G	⊙	channel input 2 (-)
Input H	⊙	channel input 3 (-)
Output I	⊗	channel indicator 1(-)
Output K	⊗	channel indicator 2(-)
Output L	⊗	channel indicator 3(-)

Technical data for CP33LR:

High current:
 Load 230V AC 3x 500 VA max total 630 VA
 Load 110V AC 3x 250 VA max total 310 VA
 Powerloss < 1%
 Spænding 110/230VAC 50/60Hz
 ON dwell time (SoftStart) 500 ms
 OFF dwell time (SoftStop) <500 ms
 Fuse (udløsekarakteristik B) max. 10 A

Low current:
 Current consumption @ 18 VDC max. 30 mA
 Power consumption @ 18 VDC max. 0,5 VA
 Indicator outputs max. 75 mA
 All switches low input 0,5 mA
 Impulse time for ON/OFF 50-300 ms
 Cable dimensions f.eks 0,6 mm
 Cable length resistance (input) R max. 1 K-ohm



MODULE SEIRES, LIGHTDIMMER CP33LR, 3-CHANNELS, LEADING EDGE

Installation Guide

Input/Output specification

Step input = low current input D
 On/Off input = low current input E
 Channel 1 input = low current input F
 Channel 2 input = low current input G
 Channel 3 input = low current input H
 Channel 1 indicator = low current output I
 Channel 2 indicator = low current output K
 Channel 3 indicator = low current output L
 Channel 1 output = high current output 4
 Channel 2 output = high current output 6
 Channel 3 output = high current output 8

Activation of a switch/input for less than 50 ms is considered noise and is ignored.

Activation of a switch/input for more than 50 ms and less than 300 ms is considered a short push. Activation of a switch/input for more than 0,3 seconds is considered a long push.

Activation of a switch/input for more than 20 seconds and less than 30 seconds is Learn Mode.

Activation of a switch/input for more than 30 seconds is considered a defective input and is signaled.

Mount module(s) on the DIN rail(s) and connect all modules with bus-cables, which powers the modules and allows bus-instructions to flow. Connect fused mains (110/230vac) to the module and double-check before applying power.

CAUTION - Ensure proper cooling or ventilation as modules enter emergency mode at temperatures higher than 35° Celcius, signaled by an SOS indication on the built-in-LED's and on the indicator outputs. Hold any of the impulse-switches (F-H) for 20 seconds to bring CP33 out of emergency mode. Reduce light level to 30% or less to reduce heat while error tracking.

Under normal conditions there is no need to keep a distance between the modules to avoid heat accumulation.

When controlling inductive loads do not exceed 90% of maximum rates. For CP33 this means 90% x 630 VA @ 230VAC = 567VA.

NOTE - Detecting absence of phase or null, the channel outputs will be turned off and the built-in channel indicators will flash - short blink long pause. At the return of phase or null the channel outputs will softstart.

Factory settings

Maximum light level

Channel output 1=95% 2=95% 3=95%

Minimum light level:

Channel output 1=5% 2=5% 3=5%

Light scenes

1 Channel output 1=20% 2=20% 3=20%
 2 Channel output 1=40% 2=40% 3=40%
 3 Channel output 1=60% 2=60% 3=60%
 4 Channel output 1=80% 2=80% 3=80%

In order to re-load factory settings:

Activate all 5 low current inputs and apply power to CP33. Wait 10 seconds and release inputs.

Adjusting Maximum/Minimum levels

You may set a maximum level and minimum level for each channel.

Example, to adjust Channel 1 you enter Channel Learn Mode using channel 1 input:

Activate and hold channel 1 input for more than 20 seconds and less then 30 seconds - channel 1 indicator will start blinking and channel 1 output will blink twice.

(New: Programming Output Confirmation)

Maximum: Adjust light level and turn light Off by On/Off input. Turn light On by On/Off input.

Minimum: Adjust light level and turn light Off by On/Off input. Turn light On by On/Off input. Wait 20 seconds for light to turn off automatically.

The highest of the two adjusted levels will be recognized as the maximum level. The lowest of the two adjusted levels will be recognized as the minimum level.

- Always keep a clearly visible difference between the two levels. Maximum and minimum levels will be ignored and cancelled if the dynamic range is too small.

- Max/min Learn Mode will be skipped after 20 seconds if programming is not carried through properly.

Light scene control

CP33 controls 4 programmable light scenes. A light scene is an instruction for the C33 to simultaneously adjust the light level on all 3 channel outputs to individually predetermined settings.

Change Lightscene by activating Step input. The channel outputs can be programmed NOT to be effected when changing light scene. (ConKey programmable).

Group control

Activating the On/Off input, you control all channel outputs simultaneously. You may turn them all On or Off by a short push or adjust all light levels Up/Down by a long push.

Channel light level control

The light level of any of the 3 channel outputs may be separately adjusted.

Activating the channel inputs you control the channels outputs individually. You may turn them On or Off by a short push or adjust light levels Up/Down by a long push.

Lightscene ChangeSpeed

You may adjust the speed/time it takes to change from next lightscene to the next. (ConKey programmable).

Storing Lightscene levels

You may store the current light level for all assigned channels to work with the current light scene:

First you adjust the light level for the required channels.

Then you enter Lightscene Learn Mode:

Activate and hold Step input for more than 20 seconds and less than 30 seconds - all assigned channel indicators will blink once and outputs will blink once.

(New: Programming Output Confirmation).

You are now back into Operation Mode.



MODULE SEIRES, LIGHTDIMMER CP33LR, 3-CHANNELS, LEADING EDGE

BUS-COMMAND

CP33 can be programmed to react on bus-commands from Master-modules.

The ActionTable presents an overview.

NOTE:

If you the light to fade in or out to a certain level, you must enter the function in ConKey in a special order, - first the time it should take to fade, then the level you want to reach.

Example: Within 30 seconds, fade to 70%.

F1: Fade 30 sec

F2: Light 70%

Fadetime:

Used to dim the light over a shorter or longer periode. For example in cinemas, etc.

Fadetime:

The fadetime is the calculated time to dim from 0 to 100% light.

I.e. if light is already on 50%, and receives the command:

Within 10 seconds regulate to 100% the light will be regulated from 50% to 100 in 5 seconds.

ConBus commands:

Action via CP-Bus	CONKEY
Turn On	On
Turn Off	Off
Touch (toggle On/Off)	Impulse
On for 15 seconds	On 15 s
On for 30 seconds	On 30 s
On for 45 seconds	On 45 s
On for 1 minut	On 1 m
On for 5 minutes	On 5 m
On for 10 minutes	On 10 m
On for 15 minutes	On 15 m
On for 20 minutes	On 20 m
On for 30 minutes	On 30 m
On for 45 minutes	On 45 m
On for 60 minutes	On 60 m
Off after 15 seconds	Off > 15 s
Off after 30 seconds	Off > 30 s
Off after 60 seconds	Off > 60 s
Off after 5 minutes	Off > 5 m
Off after 15 minutes	Off > 15 m
Off after 30 minutes	Off > 30 m
Off after 60 minutes	Off > 60 m
Blocking	Block
Help relay function	Aux relay
Increase light level	Light up
Decrease light level	Light down
Lightlevel 10%	Light 10%
Lightlevel 20%	Light 20%
Lightlevel 30%	Light 30%
Lightlevel 40%	Light 40%
Lightlevel 50%	Light 50%
Lightlevel 60%	Light 60%
Lightlevel 70%	Light 70%
Lightlevel 80%	Light 80%
Lightlevel 90%	Light 90%
Lightlevel 100%	Light 100%
Fade 5 seconds	Fade 5 s
Fade 10 seconds	Fade 10 s
Fade 20 seconds	Fade 20 s
Fade 30 seconds	Fade 30 s
Fade 1 Minut	Fade 1 m
Fade 5 minutes	Fade 5 m
Fade 15 minutes	Fade 15 m
Scene 1	Scene 1
Scene 2	Scene 2
Scene 3	Scene 3
Scene 4	Scene 4
Next scene	Scn up
Previous scene	Scn down

PROGRAMMING VIA CONKEY

Programming of CP33 from a CP79 Conkey, requires that the ConKey is updated to version 2.14 or later.

CP33 has 33 funktion-locations and 4 light scenes with associated light level and fade time.

The 33 funktion-locations are called F1-F33.

The 4 lightscenes are called Sxy (x = light scene 1-4 y = channel 1-3)

Each channel in each lightscene can be programmed to a light level (steps of 5%):

D1:95

--- = Not effected

0 = 0% (turned off)

100 = 100% (fully on)

And you can specify the period of time it should take to reach this level:

S:8

8 = Now

7 = 1 second

6 = 2 seconds

5 = 5 seconds

4 = 15 seconds

3 = 30 seconds

2 = 1 minute

1 = 5 minutes

0 = 15 minutes

