

Programming of CONCEPT 2000

Programming of the CONCEPT 2000 modules proceeds with the aid of the menu-driven IR remote control unit CONKEY with LED display. Data transfer between module and CONKEY proceeds via infrared signals. The communication is two-way and requires positioning of CONKEY either above or below the module (see figure at right).

To ensure that only one module at a time is programmed, the distance between remote control unit and module may not exceed 5 cm. During data transfer. The sending and receiving diodes are placed to the left of the module, and the remote control unit must therefore be directed towards these diodes during data transfer (see figure at right).

On error-free transfer, the modules will either return the message "Data transferred" or the message "Data received", according to whether data were fetched from or sent to the module. On error, the display will show "No contact". On reading of data already programmed, the display will show module type and address (no. 1-200). The remote control unit contains a memory in which module setup data can be saved, i.e. up to 200 modules can be preprogrammed and saved for later use.

Various AND functions (max. 8) can be programmed in to the Switch-Link type CP20 (link no. 1-4), and group functions can be programmed in so that central controls are possible. The input signals (input 1-8) can also be inverted.

Various remote control types and channel ranges can be programmed in to the IR Link type CP 70A (Link-no. 1-4), so that CP70 will ensure that the correct commands are sent out on the data line.

BO-Link type CP 70B (Link-nr. 1-4) can be programmed with module no., operation mode is selected via wiring (see product info).

Up to 40 functions (see table of functions) can be programmed into the relay modules CP 24 and dimmer module type CP 31 (3 versions). Special functions for the direct control inputs can furthermore be programmed into relay modules type CP 24 (see product info). Various lighting situations can be programmed into the dimmer. Link-no. (Switch-Link or Remote-Link No. 1-4) and channel number or AND-no. must be keyed in for each programming. On reception of these signals over the data line, the functions programmed in are carried out.

The Conkey software is constantly being updated.

Detailed user manual is included the conkey.

Placing of send and receive diodes in relay module type CP 24

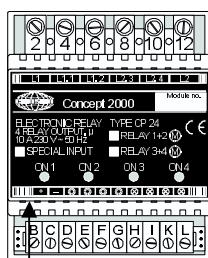
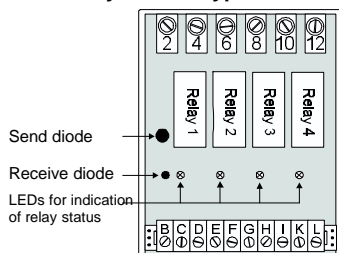

Data transfer with CONKEY type CP 79

Sending and reception of data proceed as illustrated in the figure below. As data transfer is via infrared signals, no wired connection to the system is required.

Programming and data transfer with Con Tool 2000:

Con Tool is an alternative. On the PC screen a clear and editable matrix display with all the modules in the project is shown. By means of a interface, which is connected to serial port on the PC, it is via IR communication possible to transfer data to or from a Conkey or directly to or from the various modules in the switchboard.

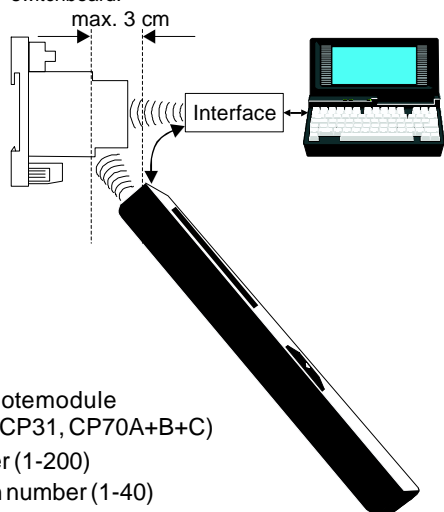

T: Modultype

Input, relay, dimmer and remotemodule (type CP20, CP24 (CP 24S), CP31, CP70A+B+C)

N: Module number (1-200)

F: Function number (1-40)

Scroll back

Scroll up (volume/channel up)

Scroll forward

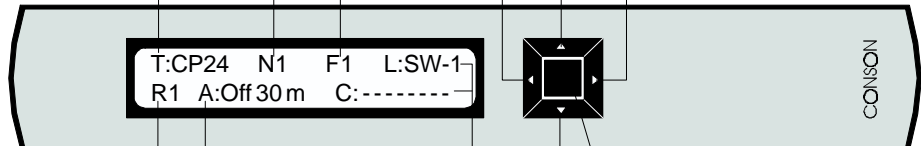

A: Action (see table of functions for active modules)

Centre button = Enter for general use, sending etc.

Scroll down (volume/channel down)

R: Relay number (1-4, only CP24, no relay in CP31)

L: Link-type Remote controls (Switch-/IR-/BO-/TL-Link)
C: Channelno. (1-8)



Programming of CONCEPT 2000

Example 1

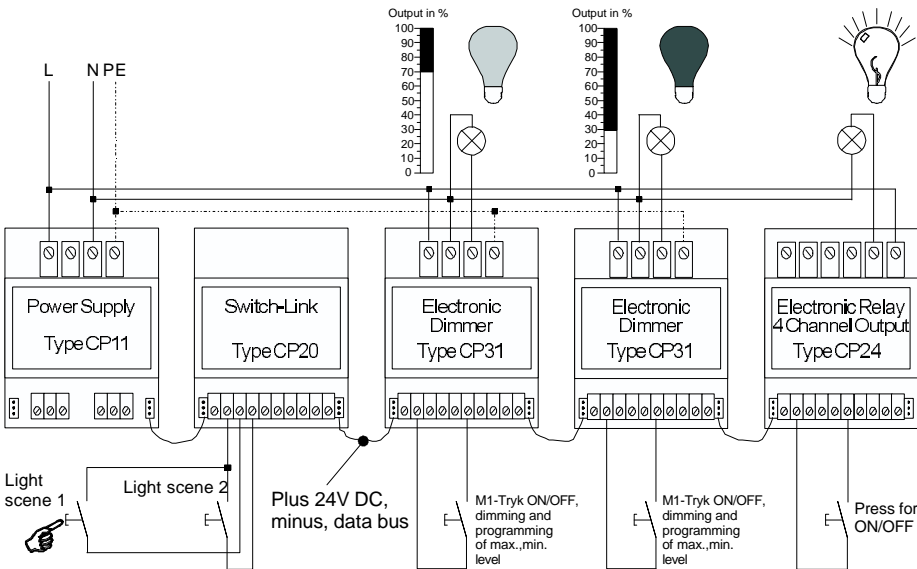

Programming example 1.

The diagram to the left illustrates an installation with two lighting areas together with the Conkey displays for the various modules. This example shows selection of lighting area 1, illustrated graphically by a column or a light bulb at the modules outputs. Min. and max. level can be programmed into the dimmers via external button switches. Switch-Link CP20, relay module CP24 and light dimmers CP31 are programmed and addressed via Conkey.

Programmed data and address CP 20, module no.1:

```
T:CP20 N1 Link No.: 1
AND No. 1:
```

Programmed data and address CP 31 module no.2:

```
T:CP31 N2 F1 L:SW -1
R- A: Light 70% C1-----
```

Programmed data and address CP 31, module no.3:

```
T:CP31 N3 F1 L:SW -1
R- A: Light 30% C1-----
```

Programmed data and address CP 24, module no.4:

```
T:CP24 N4 F1 L:SW -1
R4 A: On C1-----
```

Example 2

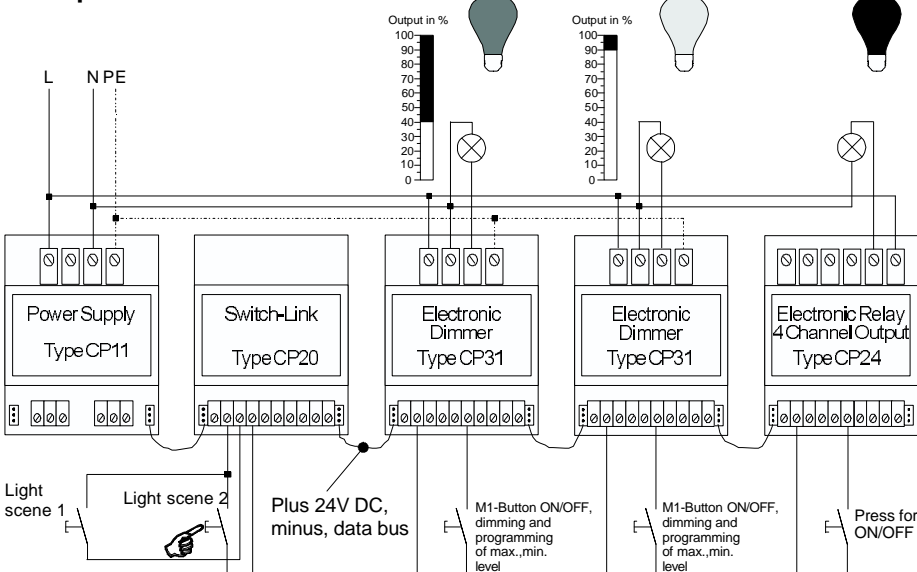

Programming example 2.

This example shows the same situation but with the lighting in area 2. The output parameters are again displayed graphically. Switch-Link CP20 and relay module CP24 are also addressed and programmed here from CONKEY. The illustrations below show the CONKEY display of the programmed data.

Programmed data and address CP 20, module no.1:

```
T:CP20 N1 Link No.: 1
AND No. 1:
```

Programmed data and address CP 31 module no.2:

```
T:CP31 N2 F1 L:SW -1
R- A: Light 40% C2-----
```

Programmed data and address CP 31, module no.3:

```
T:CP31 N3 F1 L:SW -1
R- A: Light 90% C2-----
```

Programmed data and address CP 24, module no.4:

```
T:CP24 N4 F1 L:SW -1
R4 A: Off C2-----
```

